

Ficha técnica :

150 AETJ-C



Capacities		Métrico	Imperial
Working height	h21	15 m	49 ft 3 in
Platform height	h7	13 m	42 ft 8 in
Max. outreach	r1	7.6 m	24 ft 11 in
Overhang	h31	7 m	23 ft
Pendular arm rotation (top / bottom)		+65 ° / -65 °	+65 ° / -65 °
Platform capacity	Q	200 kg	441 lbs
Turret rotation		355 °	355 °
Platform rotation (right / left)		66 ° / 59 °	66 ° / 59 °
Number of people (inside / outside)		2 / 2	2 / 2
Weight and dimensions			
Platform weight*		6700 kg	14771 lbs
Platform dimensions (length x width)	lp / ep	0.92 m x 1.2 m	3 ft x 3 ft 11 in
Overall width	b1	1.5 m	4 ft 11 in
Overall length	l1	6.05 m	19 ft 10 in
Overall height	h17	1.97 m	6 ft 6 in
Overall length (stowed)	l9	4.4 m	14 ft 5 in
Overall height (stowed)	h18	2.08 m	6 ft 10 in
Floor height (access)	h20	0.4 m	1 ft 4 in
Jib length	l13	1.26 m	4 ft 2 in
Counterweight offset (turret at 90°)	a7	0.12 m	5 in
Internal turning radius (over tyres)	b13	1.87 m	6 ft 2 in
External turning radius	Wa3	3.96 m	13 ft
Tailswing		0.12 m	5 in
Ground clearance at centre of wheelbase	m2	0.14 m	6 in
Wheelbase	y	2 m	6 ft 7 in
Performances			
Drive speed - stowed		5 km/h	3.1 mph
Drive speed - raised		0.6 km/h	0.4 mph
Gradeability		22 %	22 %
Permissible leveling		3 °	3 °
Wheels			
Tyres type		Solid non-marking tires	Solid non-marking tires
Drive wheels (front / rear)		0 / 2	0 / 2
Steering wheels (front / rear)		2 / 0	2 / 0
Braking wheels (front / rear)		0 / 2	0 / 2
Engine/Battery			
Electric engine power rating		2 x 4.5 kW	2 x 4.5 kW
Electric Pump		3.7 kW	3.7 kW
Battery / Batteries capacity		48 V / 240 Ah	48 V / 240 Ah
Integrated charger (V / Ah)		48 V / 30 Ah	48 V / 30 Ah
Miscellaneous			
Number of cycles with STD Battery (HIRD)		46	46
Ground Pressure		13.5 daN/cm ²	195.8 PSI
Hydraulic Pressure		210 Bar	14 PSI
Hydraulic tank capacity		15 l	3.96 US gal
Vibration on hands/arms		< 2.5 m/s	< 8.2 ft/s
Standards compliance			
This machine is in compliance with:		European directives: 2006/42/EC- Machinery (revised EN280:2013) - 2004/108/EC (EMC) - 2006/95/EC (Low voltage)	European directives: 2006/42/EC- Machinery (revised EN280:2013) - 2004/108/EC (EMC) - 2006/95/EC (Low voltage)

Diagramas de carga

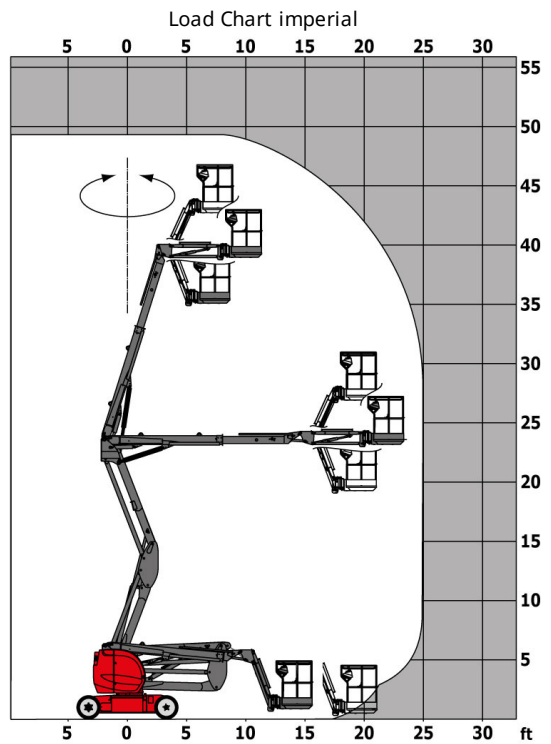
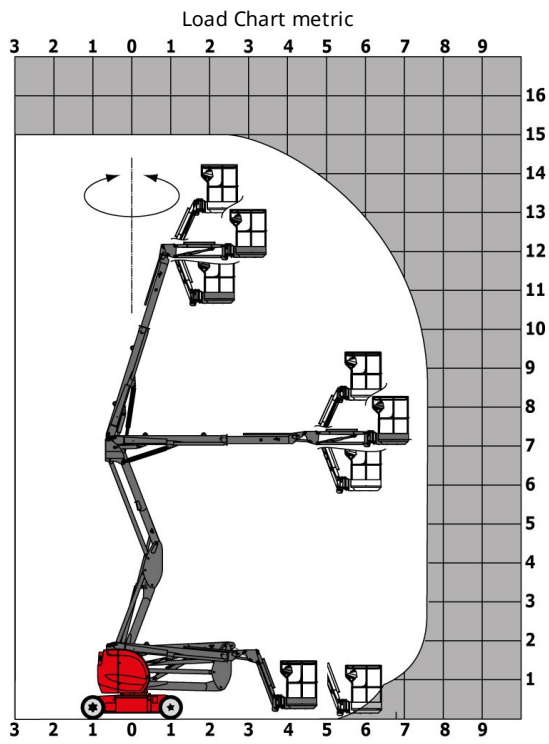

Esquemas dimensionais

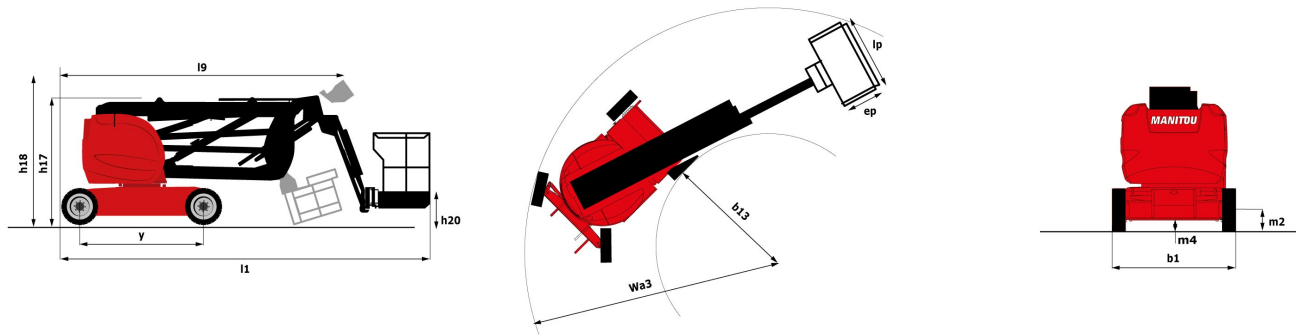

Equipamentos

Standard

- 230V Predisposition
- Audible alarm and illuminated indicator lamp (leveling, overload, lowering)
- Battery charge indicator lamp
- CAN bus technology
- Easy Manager
- Emergency stop button in platform and on frame
- Horn in the platform
- Hour meter
- Integrated diagnostic assistance
- Manual emergency lowering
- Multi-voltage integrated charger
- Negative-type braking on rear wheels
- Non-marking rubber tyres
- Pendular arm
- Platform with open-work floor
- Proportional controls
- Slings and securing rings
- Tool box in platform
- Traction battery
- Travel possible at maximum height

Opcional

- 110 or 230V plug with differential circuit breaker
- 3D
- Air predisposition
- Beep on every movement
- Beep upon travel
- Biodegradable oil
- Centralized recharging of battery
- Extreme cold oil
- Flashing Light
- Highly capacity battery
- Maintenance-free battery
- Personalized paintwork
- Protective cover for control panel
- SMS : Safe Man System
- Safety harness

Optional

Water predisposition

Working headlight in platform

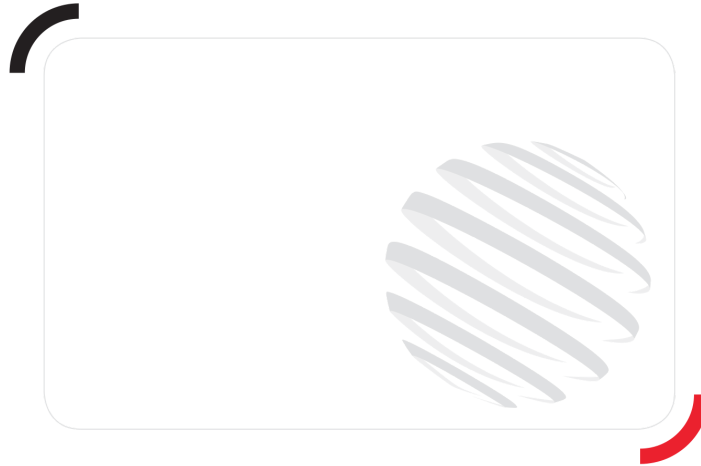

Siège Social
430 rue de l'Aubinière - 44150 Ancenis Cedex - France
Tel: +33(0)2 40 09 10 11 - Fax: +33 (0)2 40 09 10 97
www.manitou.com



Esta publicação apresenta uma descrição das versões e possibilidades de configuração dos produtos Manitou que podem possuir equipamentos diferentes. Os equipamentos apresentados nesta brochura podem ser de série, em opção ou não estarem disponíveis conforme as versões. A Manitou reserva o direito de modificar, em qualquer momento e sem pré-aviso, as especificações descritas e representadas. As especificações referidas não comprometem o fabricante. Para mais informações, contactar o seu concessionário Manitou. Documento não contratual. Apresentação de produtos não contratual. Lista de especificações não exaustiva. Os logótipos, assim como a identidade visual da empresa, são propriedade da Manitou e não podem ser utilizados sem autorização. Todos os direitos reservados. As fotografias e os esquemas contidos na presente brochura só são fornecidos para fins de consulta e a título indicativo. MANITOU BF SA – Sociedade anónima com conselho de administração - Capital social: 39 668 399 euros - 857 802 508 RCS Nantes