

Ficha técnica :

MI 25 G



Technical characteristics			Métrico	Imperial
1.1	Manufacturer		Manitou	Manitou
1.2	Model Name		MI 25 G	MI 25 G
1.3	Power source		Lpg	Lpg
1.4	Operator type		Seated	Seated
1.5	Max. capacity	Q	2500 kg	5512 lbs
1.6	Load centre of gravity	c	500 mm	19.685 in
1.8	Load distance, centre of drive axle to fork	x	465 mm	18.307 in
1.9	Wheelbase	y	1600 mm	62.992 in
Weight				
2.1	Service weight		3895 kg	8587 lbs
2.2	Weight on front axle (laden) / rear axle (laden)		5665 kg / 730 kg	12489 lbs / 1609 lbs
2.3	Weight on front axle (Unladen) / rear axle (Unladen)		1665 kg / 2230 kg	3671 lbs / 4916 lbs
Wheels				
3.1	Tyres type		PPS	PPS
3.2	Dimensions of front wheels		7.00-12 12	7.00-12 12
3.3	Dimensions of rear wheels		6.00-9 10	6.00-9 10
3.5	Number of front wheels / rear wheels		2 / 2	2 / 2
3.5.2	Number of drive wheels		2	2
3.6	Front wheel gauge	b10	965 mm	37.992 in
3.7	Rear wheel gauge	b11	973 mm	38.307 in
Dimensions				
4.1	Tilt of Mast Forward (deg) / Backward (deg)	α / β	6 / 12	6 / 12
4.7	Height of overhead guard (cabin)	h6	2115 mm	83.268 in
4.8	Seat height/stand height	h7	1190 mm	46.85 in
4.12	Height of towing bar (coupling height)	h10	360 mm	14.173 in
4.19	Overall length	l1	3685 mm	145.079 in
4.20	Length to face of forks	l2	2535 mm	99.803 in
4.21	Overall width	b1	1155 mm	45.472 in
4.22	Forks section / width / length	s / e / l	40 mm x 122 mm / 1150 mm	1.575 in x 4.803 in / 45.276 in
4.23	Fork carriage ISO 2328 (class/form) A/B		FEM 2A	FEM 2A
4.24	Fork carriage width	b3	1038 mm	40.866 in
4.31	Ground clearance below mast	m1	115 mm	4.528 in
4.32	Ground clearance at centre of wheelbase	m2	175 mm	6.89 in
4.33	Aisle width for 1000 x 1200 pallet widthways	Ast	3930 mm	12893 ft 8 in
4.34	Aisle width for 800 x 1200 pallet lengthways	Ast	4130 mm	13549 ft 10 in
4.35	Turning radius	Wa	2265 mm	89.173 in
4.36	Internal turning radius (over tyres)	b13	145 mm	5.709 in
Performances				
5.1	Travel speed (laden / unladen)		19.4 km/h / 19.7 km/h	12.1 mph / 12.2 mph
5.2	Lifting speed (laden / unladen)		0.47 m/s / 0.55 m/s	1.54 ft/s / 1.8 ft/s
5.3	Lowering speed (laden / unladen)		0.5 m/s / 0.5 m/s	1.64 ft/s / 1.64 ft/s
5.5	Drawbar pull (Laden / Unladen)		1700 daN / 1040 daN	1700 daN / 1040 daN
5.7	Gradeability (laden / unladen)		20 % / 20 %	20 % / 20 %
5.10	Service brake		Hydraulic	Hydraulic
Engine				
7.1	Engine brand / model		GCT (ex-Nissan) / K25	GCT (ex-Nissan) / K25
7.2	Engine power according to ISO 1585		35 kW	35 kW
7.3	Rated speed		2400 rpm	2400 rpm
7.4	Number of cylinders / Capacity of cylinders		4 - 2488 cm ³	4 - 151.83 in ³
7.5	Fuel consumption according to VDI cycle		6.3 l/h	6.3 l/h
Miscellaneous				
8.2	Working hydraulic pressure for attachments		160 Bar	11 PSI
8.3	Oil flow rate for attachments		72 l/min	72 l/min
8.4	Measured/guaranteed mean noise level at the ear of the operator		< 80 dB(A)	< 80 dB(A)

Esquemas dimensionais

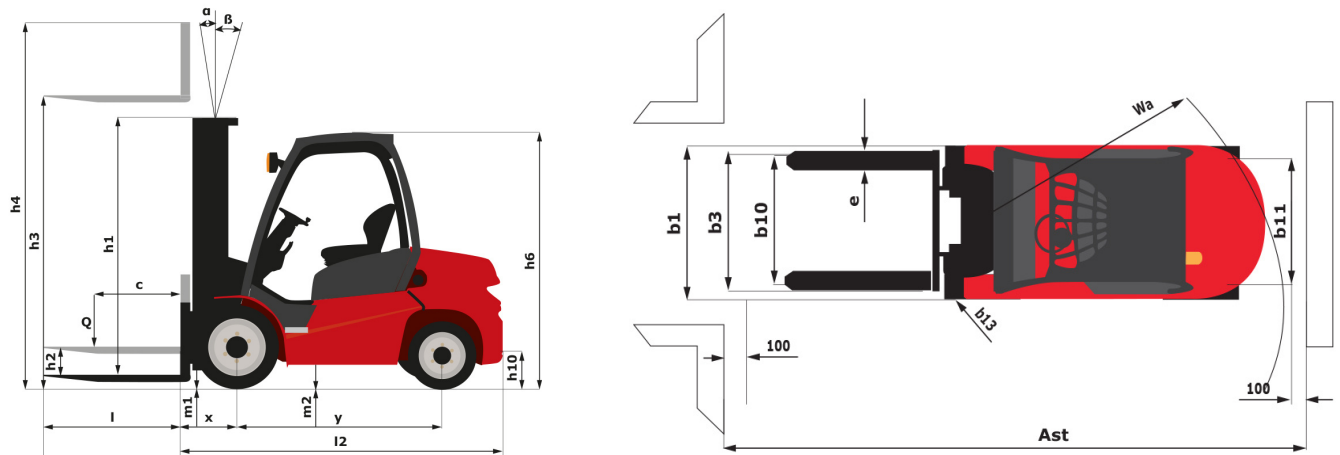

Características dos mastros e cargas residuais

Full Visibility Duplex		FVD 33	FVD 37	FVD 40
h1 - Height mast lowered *	mm	2185	2435	2635
h2 - Free lift	mm	140	140	140
h3 - Lifting Height	mm	3300	3700	4000
h4 - Height mast extended *	mm	3960	4360	4660
α / β - Mast inclination (front / rear)	°	6 / 12	6 / 12	6 / 12
Residual capacity at max height	kg	2500	2500	2500
Height at max capacity	mm	3300	3700	4000
Height at max capacity with integrated sideshift	mm	3300	3700	4000
Residual capacity without attachment (Industrial load chart)	kg	2500	2500	2500
Residual capacity with integrated side shift (Industrial load chart)	kg	2500	2500	2500
Height at max capacity Fork positioner + DL	mm	3300	3700	4000

Free Lift Duplex		FLD 33	FLD 37	FLD 40
h1 - Height mast lowered *	mm	2160	2360	2560
h2 - Free lift	mm	1480	1680	1880
h3 - Lifting Height	mm	3300	3700	4000
h4 - Height mast extended *	mm	3980	4330	4680
α / β - Mast inclination (front / rear)	°	6 / 12	6 / 12	6 / 12
Residual capacity at max height	kg	2500	2500	2500
Height at max capacity	mm	3300	3700	4000
Height at max capacity with integrated sideshift	mm	3300	3700	4000
Residual capacity without attachment (Industrial load chart)	kg	2500	2500	2500
Residual capacity with integrated side shift (Industrial load chart)	kg	2500	2500	2500
Height at max capacity Fork positioner + DL	mm	3300	3700	4000

Free Lift Triplex		FLT 43	FLT 45	FLT 47	FLT 48	FLT 50	FLT 55	FLT 60	FLT 65
h1 - Height mast lowered *	mm	2100	2150	2200	2250	2300	2500	2750	2900
h2 - Free lift	mm	1400	1470	1520	1570	1620	1820	2070	2200
h3 - Lifting Height	mm	4300	4500	4700	4800	5000	5500	6000	6500
h4 - Height mast extended *	mm	5000	5230	5380	5480	5680	6180	6730	7200
α / β - Mast inclination (front / rear)	°	6 / 6	6 / 6	6 / 6	6 / 6	6 / 6	3 / 6	3 / 6	3 / 6

Free Lift Triplex		FLT 43	FLT 45	FLT 47	FLT 48	FLT 50	FLT 55	FLT 60	FLT 65
Residual capacity at max height	kg	2400	2350	2200	2200	1950	1650	1050	1000
Height at max capacity	mm	4000	4000	4000	4000	4000	4000	4000	
Height at max capacity with integrated sideshift	mm	4000	4000	4000	4000	4000	4000	4000	
Residual capacity without attachment (Industrial load chart)	kg	2400	2350	2200	2200	1950	1650	1050	1000
Residual capacity with integrated side shift (Industrial load chart)	kg	2350	2300	2150	2150	1900	1600	1000	950



Siège Social
430 rue de l'Aubinière - 44150 Ancenis Cedex - France
Tel: +33(0)2 40 09 10 11 - Fax: +33 (0)2 40 09 10 97
www.manitou.com



Esta publicação apresenta uma descrição das versões e possibilidades de configuração dos produtos Manitou que podem possuir equipamentos diferentes. Os equipamentos apresentados nesta brochura podem ser de série, em opção ou não estarem disponíveis conforme as versões. A Manitou reserva o direito de modificar, em qualquer momento e sem pré-aviso, as especificações descritas e representadas. As especificações referidas não comprometem o fabricante. Para mais informações, contactar o seu concessionário Manitou. Documento não contratual. Apresentação de produtos não contratual. Lista de especificações não exaustiva. Os logótipos, assim como a identidade visual da empresa, são propriedade da Manitou e não podem ser utilizados sem autorização. Todos os direitos reservados. As fotografias e os esquemas contidos na presente brochura só são fornecidos para fins de consulta e a título indicativo. MANITOU BF SA – Sociedade anónima com conselho de administração - Capital social: 39 668 399 euros - 857 802 508 RCS Nantes